

Check Valve

CNT



Features and Handling

- CNT Series are check valve with optional cracking pressure. The valves allow free flow in one direction and shut-off in the other direction. The valves come with flow rate ranges from 25L/min to 190 L/min and port size from 3/8" to 1-1/4".

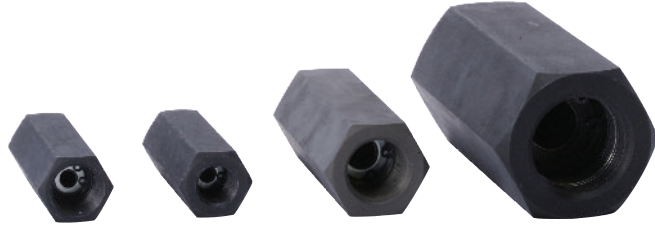

Ordering Code

CNT

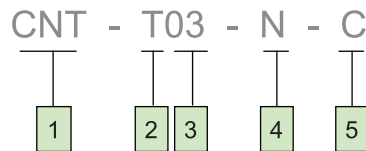

1 Model : CNT

4 Port Connection (Threaded connections only)

2 Mounting

- T - Threaded connections
- G - Gasket mounting (size 03,06 and 10 only)

CNT-T03

Code	Thread size
N	3/8" NPT
P	3/8" BSPT

CNT-T04

Code	Thread size
N	1/2" NPT
P	1/2" BSPT

3 Valve size

- 03 - 3/8"
- 04 - 1/2"
- 06 - 3/4"
- 08 - 1"
- 10 - 1-1/4"

CNT-T06

Code	Thread size
N	3/4" NPT
P	3/4" BSPT

CNT-T08

Code	Thread size
N	1" NPT
P	1" BSPT

CNT-T10

Code	Thread size
N	1-1/4" NPT
P	1-1/4" BSPT

5 Cracking Pressure

- A - 0.4 bar (5 psi)
- B - 3.5 bar (50 psi)
- C - 5.0 bar (70 psi)

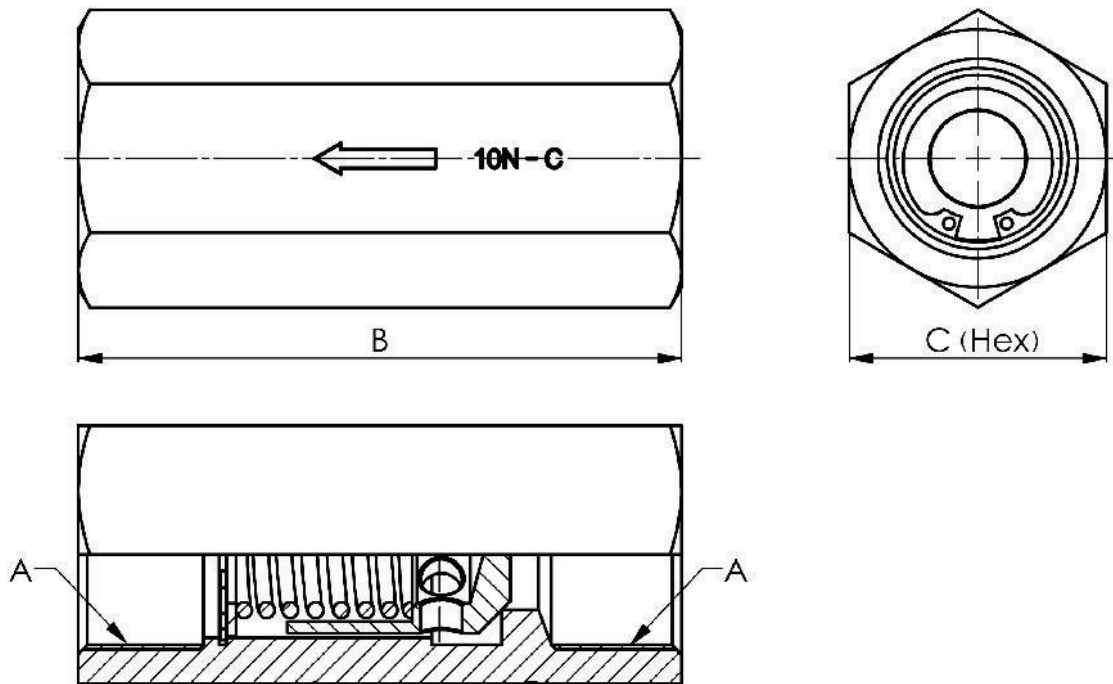

Model	Maximum Flow L/min (USgpm)	Maximum Pressure bar (psi)	Dimensions mm (inch)				Weight kg (lb)
			A		B	C	
			NPT	BSPT			
CNT-T03	25 (6.6)	210 (3000)	3/8"NPT	3/8"BSPT	70 (2.76)	24 (0.94)	0.20 (0.44)
CNT-T04	30 (7.9)		1/2"NPT	1/2"BSPT	70 (2.76)	27 (1.06)	0.25 (0.55)
CNT-T06	45 (19.8)		3/4"NPT	3/4"BSPT	95 (3.74)	38.1 (1.50)	0.68 (1.50)
CNT-T08	150 (39.6)		1"NPT	1"BSPT	113 (4.45)	47.5 (1.87)	1.24 (2.73)
CNT-T10	190 (50.1)		1-1/4"NPT	1-1/4"BSPT	130 (5.12)	55.5 (2.18)	1.83 (4.03)